

USJ
GAN
GG
[繋ぐ]



広げろ Expand Special Issue

Paper Animals

Paper texture brings life to crafting

深める+ KPP's efforts to tackle issues with plastic waste

先どる Paper Items for Travel Add more comfort to your journey

広げる 01

Expand
Paper Animals:
Paper texture brings life to crafting

先どる 07

Advance
Paper Items for Travel:
Add more comfort to your journey

伝える 09

Communicate
A letter filled with care and attention
from a director who was a true original

深める+ 11

Deepen Plus
KPP's Efforts to Tackle Issues
with Plastic Waste

深める 13

Deepen
Catch Up on the Latest News at KPP

出会う+ 14

Meet Plus
A fascinating glimpse into KPP offices
outside of Japan
A Guide to KPP Personnel

訪ねる 15

Visit
Get a real sense of the allure of paper
The Paper Event Calendar

作る Supplement

Create
Braided Bird Plate by Yasuyuki Wada

Paper texture brings life to crafting Paper Animals

A single piece of paper is cut, bent, and fastened together to create expressive shapes that make use of the unique characteristics of different papers. Paper crafts are one of the most popular arts, and Japan has garnered a great deal of attention around the world as a country with a highly evolved paper crafting tradition. Yasuyuki Wada is a paper craft artist who uses papers of different textures and colors to create singularly realistic animals. Made from a single sheet of paper, these dynamic animal crafts overflow with warm charm, fascinating young and old alike.

We asked Wada to share his thoughts about the joys of paper crafting with us.



“Making three-dimensional animals from a flat sheet gives the paper a whole new quality.”

ANIMAL



Yamatani Standing Paper Zoo (2011-2012)

A miniature zoo kit featuring 20 different animal figures and a natural diorama. In addition to those pictured, the kit includes such popular animals as elephants, lions, koalas, and alpacas.

“I started doing paper crafts when I was a student in art school. I had planned an exhibition and workshop for elementary school students and created paper crafts of traditional Japanese school bags for display. I saw the expressions on the kids’ faces when they saw my work and watched them become totally engrossed in folding paper, and I knew then I wanted to do something that conveys the joy of making things. For my graduation project, I created a paper craft picture book that helps readers learn about insects while shaping them from paper. After undergrad, I went on to grad school and devoted myself to designing and creating paper crafts. I’ve been creating objects with animal motifs ever since. In the beginning, I would throw objects away when I couldn’t make them work, but I began feeling guilty about crumbling up and throwing away animals once they had taken a three-dimensional shape.

Flat sheets of paper that would come to form animals seemed to me to have a life, and I became even more captivated when I realized how amazing it is that creating paper animals gives the paper a whole new quality. After grad school, I gave myself two years to make a living as an artist and worked hard to sell my work, mostly to design offices. At the time, I was living in Kansai, in western Japan, but I would visit Tokyo where more experienced paper craft artists were getting a lot of work. They gave me valuable advice. After that, orders for my paper crafts gradually increased, and I had the opportunity to appear on TV. I became more confident that I would be able to make a living as an artist. It was then that I decided to move to the Kanto area (around Tokyo) to find even more substantial work.”



Head Box (2014)

gu-pa’s original foray into paper craft kit products. Ideal for interior accents, these animal heads are designed in box shapes for unique gift wrapping, as well. Includes a total of five animals—hippo, deer, elephant, rabbit, and bear.



Animal Nose Masks

A paper craft set that reproduces the distinctive noses of animals. Popular at children’s workshops and other events, the nose masks come together using only tab inserts and requiring no glue. Includes a total of six animals—pig, elephant, rabbit, lion, walrus, and wolf.

How Wada Works

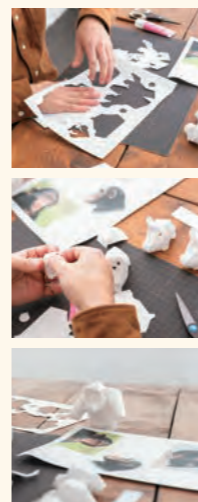

1. After determining the animal for the motif and the paper he will use, Wada then collects images of the animal photographed from different angles. Depending on the item, he may make sketches to get a clearer picture of the final work.
2. Aligning images for the front, side, and other views, Wada cuts and fastens together copy paper to create a prototype for the three-dimensional work. He uses a stylus to form creases and paper glue to keep the shape, evaluating the overall form for strength and specific gravity balance and making fine adjustments so that the animal stands stably on its own.
3. Using this prototype, Wada develops the paper pattern using a plotter. He makes the adjustments needed for assembly, adding part joints and overlap margins for glue.
4. Wada orders the steps for assembling the animal and writes instructions with illustrations for reference. If the work will be sold to consumers, it is finished with Thomson type punching processing and laser cutting. It takes approximately five months to turn his original idea into the end product.

Yasuyuki Wada
Paper Craft Artist



Born in 1982 in Osaka Prefecture. Lives in Chiba Prefecture. Graduated in 2006 from the Department of Product Design, Kobe Design University and in 2008 from the Graduate School of Arts and Design, Kobe Design University. His professional artistic debut came with a collaborative exhibition with illustrator Junzo Terada. In addition to creating work for magazines, Wada is active in a wide range of media, including exhibitions, workshops, and television appearances. Since 2014, he has designed products for the paper craft kit brand gu-pa. Official website: www.injan.net

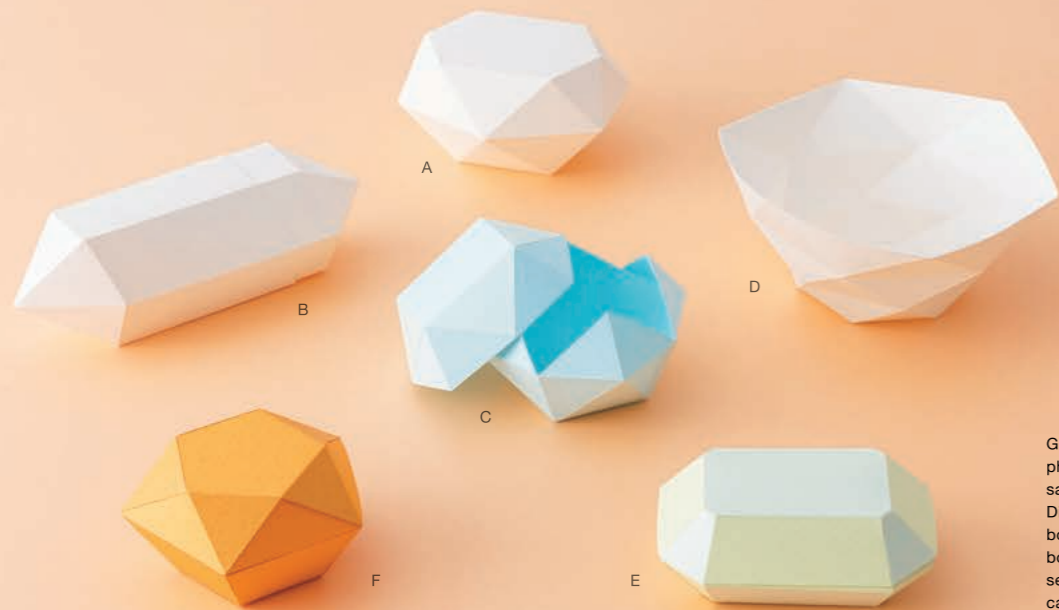

Gemstone Boxes (A –E in photo: crystal, emerald, sapphire, and ruby) and Diamond Box (F). The lid and bottom of the gemstone boxes are assembled separately to pull apart and can be used to hold small items or as a gift box.

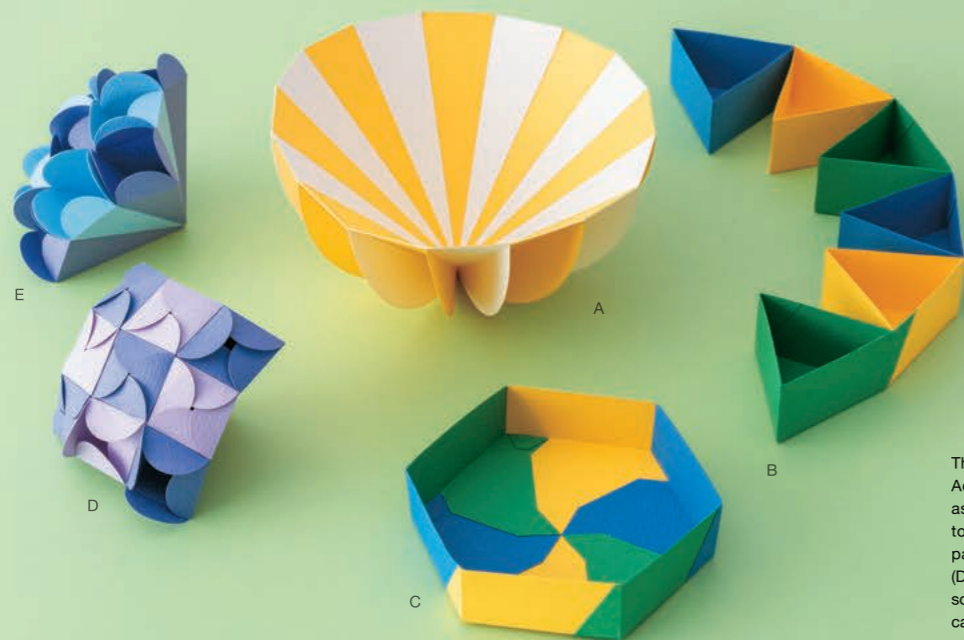

The Striped Bowl (A) and Small Adjoining Boxes (B & C) are assembled by fastening together multiple identical parts. The Hydrangea Boxes (D & E) are made of clusters of square pyramid, and the petals can be closed to form a gift box.

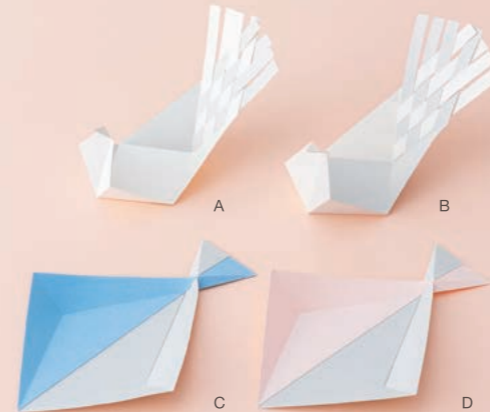

The Braided Bird Plates (A & B) and Fish Plates (C & D) take their inspiration from these creatures. Use them as an accent around the house or as tableware in the dining room.



Ornamental Paper Ribbons (A & B) offer added decoration for gift boxes. The paper accessories are also popular with women looking for paper items to wear.



House Boxes (A, B, & C) are created in two parts with lids and bottoms that can be separated. The Medal Brooch (D) and Star Ornament (E) are for decorative use, while the Honeycomb Tray (F) made by connecting hexagons in any pattern can be used to hold small items.

PRODUCTS

Paper Craft Kit gu-pa

In 2014, the paper craft kit product brand gu-pa was launched as a collaborative project between Wada and Fukunaga Print. The project has produced three series so far—Head Box, Face Pop-up Card, and Top to Tail. These series can be purchased at the Fukunaga Print online store, KAMIGU.

Website (gu-pa Products) www.fukunaga-print.co.jp/gu-pa

Online Store www.kamigu.jp



BOOK

Yasuyuki Wada Book *Kami no Hako to Utsuwa* ("Paper Boxes and Containers")

2013, Bunka Publishing Bureau

The first book to bring together practical paper crafts that make everyday life more fun. In addition to providing the paper pattern and instructions for each craft, the book also presents special paper-folding methods to introduce readers to the joys of making objects with paper.



Motifs based on the qualities of different papers to create realistic animals

"A few years after I started working as an artist, an editor who had seen my work got in touch, and we published a book. The theme was paper boxes and containers, and the book featured 25 different paper crafts with instructions for how to make them. This was a great opportunity to re-experience paper, to enjoy it in practical ways and bring the fun of creating and the joy of paper to everyday life. After the book, I invited Fukunaga Print Co., Ltd. (Tachikawa City, Tokyo) to my solo exhibition, and this led to a collaborative project with them. Fukunaga Print Co., Ltd. has produced many paper products that combine the company's printing and processing technology with designers' ideas. Together, we launched a line of paper craft kits. One of these, Top

to Tail, is a series of kits for assembling realistic animals with body parts that move. For true realism, we choose paper with qualities that are close to the actual feel and look of the animal's skin and coat. We use Croco GA, for example, which is an embossed paper with a bumpy texture like crocodile skin, to create the crocodile. Sometimes, I look at a certain type of paper and imagine what I could make, taking inspiration for the animal from the paper itself. I often use a fine paper called Mermaid for my work. I like it, because it is just stiff enough to be easy to work with and comes in a wide variety of colors with a slightly cushiony texture that feels soft. Next, I'd like to try creating objects that combine different materials, like thread, yarn and other fabrics, with paper."

Hoping to help children see the fun of making things

"One of my goals is to open a workshop studio for kids. There used to be many magazines that included paper craft kits at the back, but now most of the paper crafts we see are already made. There even seem to be fewer and fewer of these magazines so, outside of arts and crafts classes at school, kids have fewer opportunities to use paper. Paper is a very familiar, easy-to-use material. I want children to have the chance to use their own hands to turn a flat sheet of paper into a three-dimensional object and to experience the fun, the sense of achievement, and the excitement that comes with making something from scratch. It would be great if my work gave them that chance. I am currently working on a new kit for the paper craft kit series sold by Fukunaga Print. People

around the world love animals, and this motif has universal appeal. I would like to continue making classic paper toys that don't go in and out of style, toys that will be loved by children around the world for years to come."



GOLDEN WEEK 2019

Add more comfort to your journey

Paper Items for Travel

This year's Golden Week spans 10 consecutive days from Saturday, April 27 to Monday, May 6. Many people are likely planning to fill this exceptionally long vacation time with travels and other leisure activities. To help you enjoy this special time with little stress, here is a collection of paper products that will prove very useful during your activities.



Compact and easy-to-carry paper fold-up stool

Smart Paper Stool

Sold by: PiCa Corp.
<https://petsadvance.jp/contents/70>



Cow pattern



Leopard pattern

M size
When in use: W170xH253xD220
When folded up: W170xH250xD33
Maximum weight: 150kg

L size
When in use: W180xH303xD260
When folded up: W180xH300xD33
Maximum weight: 120kg

*Keep away from water.



The Smart Paper Stool is useful during outdoor leisure activities like hikes as well as waiting in line at a theme park or at events including outdoor festivals. The fold-up design requires no assembly so you can quickly open it up and use it right away. Since it is lightweight thanks to the paper material and can fold up to about the size of 210mm x 297mm, it can fit into a large backpack or tote bag for easy transport. Since it is made of paper, you might worry about it collapsing, but there is no need for concern. The durable design can support over 120 kilograms so even an adult can sit on it with no problem. This handy item you can sit on during transportation or use as a footrest at your place of lodging will provide much comfort in your travels.

01

Your feet stay dry and comfortable even after long walks with these highly functional *washi* socks!

“Kamiko” Washi Socks

Sold by: Tomoeseni Co., Ltd.
<http://tomoesenico.jp/product/kamiko/>

After walking around tourist sites for a while, feet can start to get hot and smelly. Solve this issue with Kamiko paper socks! The socks are woven using twisted *washi* paper thread made of 100% Manila hemp. The sock has a hollow center for excellent permeability and it quickly absorbs and evaporates any moisture, ensuring that feet stay cool and comfortable. Because these socks weigh only about half as much as cotton ones and are designed to fit snugly against the feet, they are perfect for travels that require long hours of walking. These highly functional socks are packed with other innovative features only possible with paper, like odor-killing material in the under thread that breaks down ammonia instantly, and a sock surface that remains pill-resistant even after washes. They are a useful must-have item for travel.



Women's come in 2 varieties:
pile short socks, and
14cm ribbed socks (both in 8 colors)

Men's come in 3 varieties:
pile short socks (in 4 colors),
14cm ribbed socks (in 4 colors), and
five-toe socks (in 2 colors)

03

Exciting cross-generational fun!
Test your memory and spontaneity
with this card game

Nanja Monja

Sold by: SUGOROKUYA <http://sugorokuya.jp>



Comes in two varieties of "White" or "Green," each containing 12 different Nanja Monja family members.

Nanja Monja is a unique card game that originated in Russia. Make up a name for the mysterious creature of the Nanja Monja family that appears on your card, and other players must remember that name. When the same card appears out of the stack, whoever calls that given name first gets to take all of the cards. There are 12 different loosely drawn Nanja Monja family members who have arms and legs growing out of their heads. Part of the fun is getting glimpses into each player's personality and sensibilities based on the names they creatively come up with, which may be based on the characters' appearances, or might just be a name that is hard to remember. A simple game that can be enjoyed by kids as young as four, it is certain fun for people of all ages. Play while traveling or during down times at your place of lodging.

04

Stylish and eco-friendly non-electric
humidifier that can be used anywhere

Rocca Paper Humidifier

Sold by: Doshisha Corporation
<https://e-doshisha.com/lineup/>



Comes in 4 varieties:
apple (2 types), orange,
and cactus

Hotels air always seems to be over-heated and over-dried by the air conditioner. This can cause sore throats and dry eyes, but this paper humidifier helps to resolve these issues. Its natural aeration mechanism siphons up water placed in a container through a filter and releases it into the air, so there is no need for electricity. It can be used anywhere and makes no bothersome noise. The honey-comb filter efficiently siphons up moisture and provides about 20 times more humidifying capability than water contained in a cup that is evaporated naturally. The antibacterial and antifungal humidifying filter makes it safe and hygienic. This adorable and eco-friendly humidifier gently adjusts the humidity of the room and will be a useful companion on your travels.

05

Organize and record memories
of your travels by making your
very own travel journals

Wanna Do!! Journal Series

Sold by: THE LOFT Co., Ltd.
<https://loft.omni7.jp/fair/c1210131001?lofttr=mediaproduce180907>

Traveling is about having fun while at the desired destinations, but it can be made more meaningful as you look back on it later. Writing down the views, sensations, and feelings encountered at the time can make your travel experiences all the more fulfilling. These "Wanna Do" journals are useful for organizing and compiling such documentations of your excursions. Follow the journal's format and paste photos and write down information, thoughts, and reviews about the places you visited. Then add other things like tickets and apply decorative tapes and you will have your very own original journal. The completed journal will be fun to look through later, and useful for planning visits to the same places and offering recommendations to friends. It will naturally improve your ability to enjoy your travels.

02



Wanna Do!! Journal Series comes in 40 varieties, including "Travel," "Travel Lodging," "Best Views," "Hot Springs," "Drives," "Buddha Statues," "Art Museums," "Theater," and "Theme Parks."



Making Letters Speak

Tomone Uemura

Humans are creatures who express their thoughts. I feel that letters are the most profound and noble form of human expression. When it comes to letters, hand-written letters are best. When we try to read between the lines, we can see the personality of the writer.

Part 17: Teruhiko KUZE

It was nearly a quarter century ago that I first met Teruhiko Kuze. It must have been in 1992. At the time, I was in charge of programming at a small TV station in Tokyo and wanted to make a series based on literary masterpieces from the Meiji era on. I was looking to build viewer trust by taking a different tack from the other stations trying to get ratings by running *torendi dorama* (a modern Japanese style of TV series that emerged in the 1980s). Having worked at a film company, I was inclined to the creative side of production, so I focused first on who would create the episodes. I asked a number of well-known directors like Hideo Onchi, Yukio Fukamachi, Katsumi Oyama, and Kon Ichikawa to direct. Teruhiko Kuze was one of them. By then, Mr. Kuze had left Tokyo Broadcasting System Television and was head of KANOX production company. I was nervous about approaching someone who had achieved so much

with productions of *Terauchi Kantaro Ikka* (“Terauchi Kantaro’s Household”), *Jikan Desu Yo* (“It’s time”), and *Mu Ichizoku* (“Family of Mu”), as well as his novels and lyrics. But this was my job, so off I went.

I explained the gist of my idea, and Kuze immediately agreed, saying that he had long wanted to do something similar. He even went as far as to say my proposal was a dream come true. Part of my job was to provide talented creatives with a channel for their work, so I was delighted, and moved, by his answer.

The show aired in May of that year with the title *Nihon Meisaku Dorama* (“Japanese Masterpiece Drama”). The first episode was Ogai Mori’s *Gan* (“The Wild Geese”) and it starred Yuko Tanaka. I rarely watched my own programming, but I watched this one at home with much satisfaction. The show was just as I hoped it would be, and I sent a letter to Mr. Kuze saying so. He replied as follows.

“Thank you for your letter. For the first time in quite a while, it feels as if I’ve truly created a TV show. Neither has it, for quite some time, felt like I’ve given my all after a shooting. I am satisfied. In the future, I think the two half-episodes could be edited into a single full episode, and the pace and tempo would work even better. I also expect the other episodes in the series to be great works.

“Let me just say I am honored to have been given this opportunity and to have been selected before more senior directors to direct the first episode. I thank you for that once again. In the May 1 and May 8 *Nihon Keizai Shimbun* culture column, I wrote about Hikari Oe and Kazuhiko Hasegawa, both of whom were involved in *Gan*. The columns appeared just before the show aired, which I thought might help with audience numbers a bit.

“I hope this series will continue to air for many years. I am

especially looking forward to seeing Kon Ichikawa’s *Shinjitsu Ichihiro* (“Way of Sincerity”). Once again, I thank you very much.”

I have included the entire letter here to show just how clever and conscientious Mr. Kuze’s writing style was. Although he made a name for himself with his comedy-dramas, literary drama may have been his true calling. Reading the letter, you hear the voice of a production company president as he thinks about how to tie this work to the next and focuses on promoting the show. One also reads in it his reverence for the director Ichikawa.

This was as close as our relationship got. However, when I left my office job and released my first book *Naoki Sanjugo-den* (“The Life Story of Sanjugo Naoki”), he gladly took part in a roundtable discussion entitled “Naoki Sanjugo to Bunshi no Jidai” (“Sanjugo Naoki and the Age of Writers”) with Tomomi Muramatsu, which was put on by the magazine *Ooru Yomimono*. I do not recall much of the discussion, but I do remember how carefully the two had read my book and how pleased the audience was with all the details they covered.

As I write, I also remember having a great time with Mr. Kuze at a party at Toriimoto in Gion, Kyoto. Makoto Fukagawa, then-president of Television Osaka, and Koichi Miyagawa, an executive at TV Tokyo, were also there. The party came about because a young actress, Tomoko Tabata, who appeared in one of Mr. Kuze’s dramas, was the granddaughter of the Toriimoto proprietors, and Mr. Kuze had produced a drama for Television Osaka. It was a lively affair with Ms. Tabata and her grandmother making an appearance and group photos taken to commemorate the evening.

At the end of the party, Mr. Kuze and I talked about shows we wanted to make. He and I were both interested in getting Takehiko Fukunaga’s *Kusa no Hana* (“Flowers of Grass”) made. We talked about this story of the loneliness of love as expressed in the love of the protagonist Shigeshi Shiomi for his friend Shinobu Fujiki; Fujiki’s death; and Shiomi’s unrequited love for Fujiki’s sister, Chieko. The book was a favorite of both of ours during our youth. I said, “More than any other, *Kusa no Hana* is the book I want to see made. It gets to me no matter how many times I read it.” Mr. Kuze replied, “After being unable to see Chieko at the recital, Shiomi gazes out the window of the night train searching for a light at Chieko’s house as he heads off to battle. How heart-wrenching.” Even now, after Mr. Kuze has left us, I still sometimes dream of *Kusa no Hana* being dramatized with as much fervor as I did in my youth.

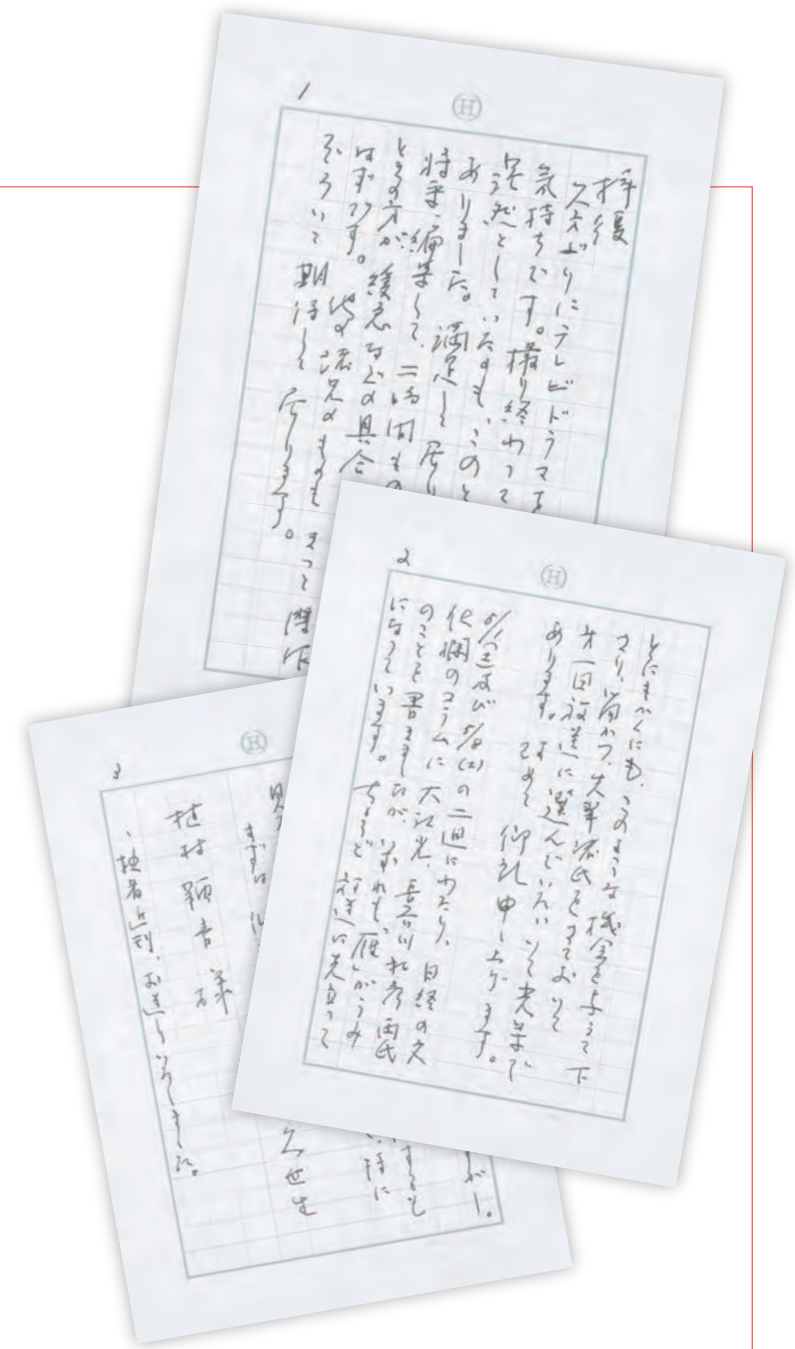

Teruhiko Kuze 1935 - 2006

Director/Lyricist/Novelist



Born in Sugunami City, Tokyo, Teruhiko Kuze graduated from the University of Tokyo’s Division of Archaeology and History of Art, Faculty of Letters. After joining Radio Tokyo (now TBS), he worked as a director and producer on a number of masterpiece television drama series that have become classics in the history of Japanese television, including *Terauchi Kantaro Ikka*, *Jikan Desu Yo*, and *Mu Ichizoku*. In his later years, Kuze was an active novelist and essayist, winning a number of awards including the Japan Record Award (lyrics) and the Izumi Kyoka Prize for Literature. In 1998, he was awarded Japan’s Medal with Purple Ribbon.



Brief Biography of the Author

Tomone UEMURA
Essayist

After graduating from the Department of History, the Faculty of Letters, Arts and Sciences at Waseda University in 1962, he worked at Toei Co., Ltd. before entering TV Tokyo Corporation, where he was later appointed to managing director of TV Tokyo and president and representative director of PROTX.

深める+ (Fukameru Plus)

KPP's Efforts to Tackle Issues with Plastic Waste

Plastic waste has become an urgent issue worldwide. Kokusai Pulp & Paper Co., Ltd. is working to resolve the issue by pursuing a variety of efforts, most notably finding paper replacements for plastic items and encouraging recycling.

Plastic waste in the seas increasing annually

Durable and lightweight as well, plastics are convenient and easy to stretch, bend and otherwise process. Being cheap to produce also, they are materials we make broad use of in our lives; not only for the necessities of food, shelter and clothing, but also for packaging, cushioning, and so on. The world produces an estimated 400 million tons of plastic annually, and of this, single-use disposables comprise about 40%. Unless they reach collection or disposal sites, these spill out into the environment, and most flow down rivers to end up in the ocean. This mass of plastic waste greatly impacts ocean ecosystems and presents a grave environmental issue that calls for an international response.

Microplastics absorption in ocean ecosystems

Forces such as coastal waves and ultraviolet rays cause the masses of plastic that spill into the ocean to disintegrate into minute particles, called "microplastics" when 5 mm or smaller.

Due to their microscopic size, it is difficult to collect these microplastics that ride the currents and spread throughout the oceans of the world, and they do not easily decompose naturally either. With cases of ingestion by fish, sea birds, and marine mammals such as seals on the rise, their effect on the bodily and reproductive health of sea life presents a topic of concern. A World Economic Forum report found that upwards of 8 million tons of plastic may be spilling into the oceans each year and predicted the gross weight of microplastics in the ocean to exceed that of fish by 2050. Experts trace the source of microplastics to sources such as scrubbing agents from face washes, abraded tire fragments and synthetic fibers shed when washing fleeces. Furthermore, as they tend to bond with polychlorinated biphenyls (PCBs), dioxins and dioxin-like compounds, research indicates fish and shellfish may accumulate pollutants harmful to humans by ingesting microplastics. This is an issue Japan cannot take lightly, as survey data shows the concentration of microplastics in seas near

Japan to be approximately 27 times the world average.



Former destination for plastic waste China bans its import

The effective utilization rate of plastic waste in Japan is among the world's highest at 84%. Still, "thermal recycling," which involves burning plastics to recover energy from them, accounts for over half of this total. Advanced European nations currently do not recognize this method as a genuine form of recycling, as it incongruously causes the release of



Exhibits at the Spring Marketing & Sales Promotion Expo (January 30 – February 1, 2019) We presented materials and products contributing to reduction of environmental impact such as: (1) paper clear files made of wax-treated paper; (2) MAPKA material containing 51% paper powder, which is shapeable like conventional plastics; (3) a diverse array of paper straws; and (4) sponge cloth, made completely of natural materials (eco-friendly cellulose developed in Germany along with cotton) that decompose in soil.

greenhouse gases. Accordingly, we must conclude that Japan is not attaining the effective and sustainable utilization of plastic resources. Moreover, while Japan had formerly exported large amounts of plastic waste to other Asian countries, China in particular, the Chinese government has completely banned the import of recyclable waste since January of last year. With the destination for Japan's plastic waste disappearing, efforts towards deplasticization have taken on an urgent tone.

Japanese government policy on plastic waste

The G7 also adopted the Ocean Plastics Charter at their summit in Canada last June. The charter establishes numeric targets for restricting, reducing and recycling single-use plastics, yet Japan and the US refrained from signing on. As the Japanese government met with criticism for this both at home and from abroad, they are now working to formulate a "strategy for recycling plastic resources."

This is to include numeric targets for recycling, with measures such as fees for single-use plastic shopping bags and biomass-based plastics production. They plan to announce the strategy at the G20 summit in Osaka this June.

Harnessing *soshiryoku** to help solve the issue

What can we do to reduce plastic waste? The 3 R's: reduce, reuse and recycle. Specifically, it is important for each of us individually to start using our own reusable bottles and bags and to find replacements for plastics such as paper or metal.

As a company aspiring to facilitate the evolution toward a recycling-oriented society, KPP works to promote efforts to resolve plastics-related issues. In one instance of this, we participate in the Ministry of Economy, Trade and Industry-sponsored Clean Ocean Material Alliance (CLOMA). CLOMA aims to offer information provision and business matching services intended to promote

effective resource utilization and the strengthening of links between businesses manufacturing materials and those making use of them. We plan to participate in the Ministry of the Environment-sponsored Plastics Smart forum as well, which aims to promote information sharing to reduce plastic waste in oceans.

At KPP, we have a slogan: *soshiryoku*.* Working to develop new paper-based possibilities, we are strengthening links between our headquarters and branches in Japan and abroad. We will continue to make contributions to the evolution to a recycling-oriented society by promoting recycling as well as working to maximize the potential of paper, which is poised to offer a replacement of plastics.

*Believing in the potential of paper and collecting information inside and outside of the company, we harness imagination and creativity to propose solutions to customers.

Production Output of Plastics

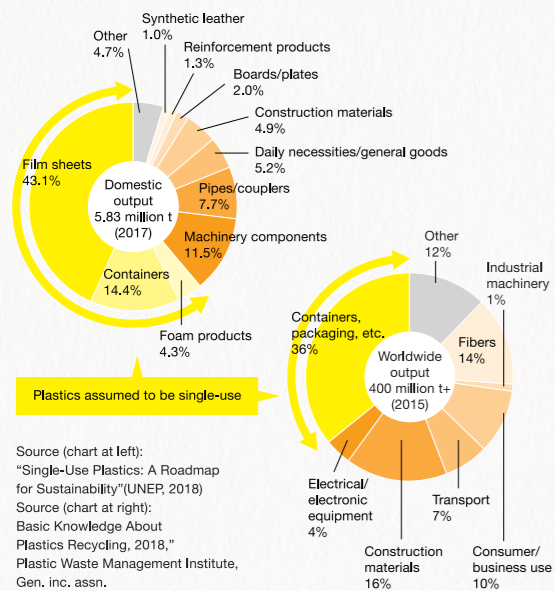

Shifts in Worldwide Plastic Production Totals

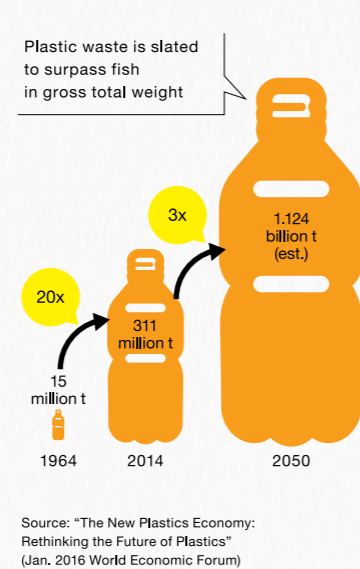

The Flow of Microplastics

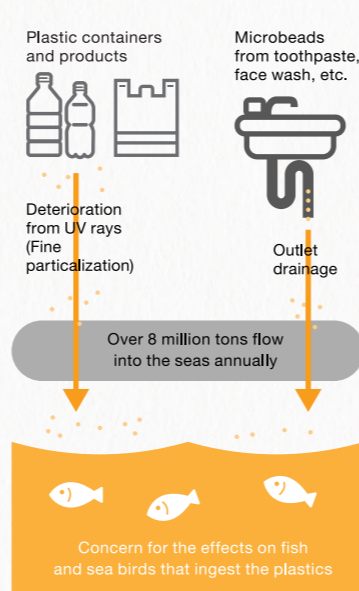

Microplastics Count by Marine Area

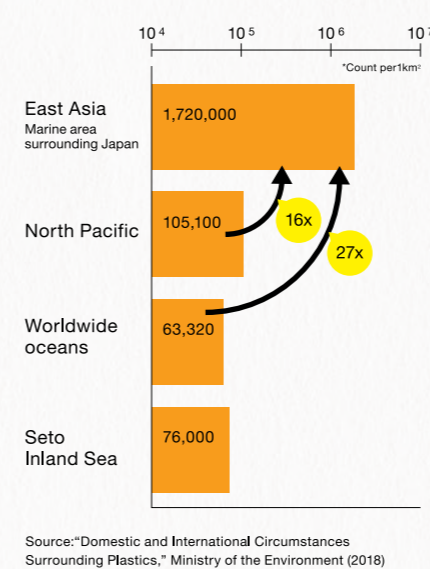

Disposal of Waste Plastics

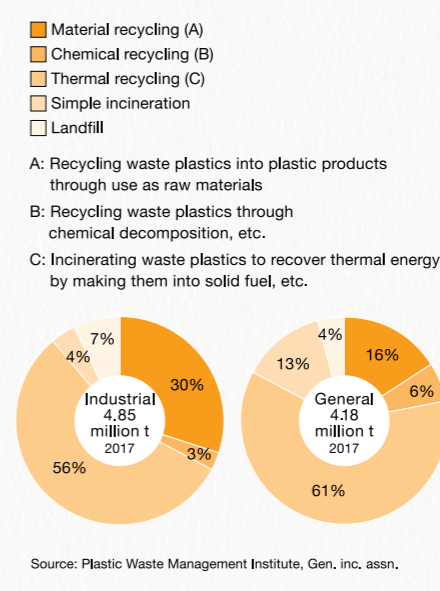

Principal Corporate Initiatives

Company	Principal Initiative
Starbucks Corporation	Phasing out plastic straws at approximately 28,000 locations worldwide by 2020
McDonald's Corporation	Replacing plastic straws with paper at all UK and Ireland locations by the end of 2019
SKYLARK HOLDINGS Co., Ltd.	Phasing out plastic straws by 2020
H & M Hennes & Mauritz AB	Switching to paper shopping bags in Japan and charging fees for them
Ryohin Keikaku Co., Ltd.	Forgoing distribution of plastic bags and straws at their new Ginza location opening in April
Kao Corporation	Switching to naturally-derived ingredients for scrubbing agents they use in face and body washes
Ito-Yokado Co., Ltd.	Charging ¥2 per single-use shopping bag
Seven & i Food Systems Co., Ltd.	Generally discontinuing plastic straws at Denny's locations

▶ Washi Papermaking Class Held at Miyanomori Elementary School in Higashimatsushima City, Miyagi Prefecture

Together with the C.W. Nicol Afan Woodland Trust, we held a *washi* papermaking class for third-grade students at Miyanomori Elementary School in Higashimatsushima City, Miyagi Prefecture, on January 15, 2019. Since 2015, our company has endorsed the Afan Earthquake Restoration Project promoted by the Afan Woodland Trust. We support this program of earthquake disaster reconstruction through activities such as reforestation and offering emotional care for children.

This was the third time we held the *washi* papermaking class after starting the event in 2016. The school children collected mulberry and paper bush planted three years ago in the forest behind the elementary school. Under the guidance of Rogier Uitenboogaart, who crafts *washi* paper by hand, the students rose to the challenge of making *washi* paper using plants they grew themselves. Creating *washi* paper was an opportunity for the children to learn about the allure of *washi* and the importance of the environment they live in. The elementary school principal, Ayumu Muraoka, had an even bigger vision, remarking that it would be wonderful if, at future graduations, diplomas were made out of paper made from the plants the children planted. Our company will continue supporting earthquake disaster reconstruction through paper.



▶ KPP YUPO® Exhibition: Tsukiji YUPO Market

With cooperation from YUPO Corporation, which will celebrate its 50th anniversary in May 2019, a two-day exhibition called Tsukiji YUPO Market held February 18 – 19 to widely communicate the merits of the synthetic paper, YUPO®. On the first-floor entrance space at the Head Office, numerous examples were introduced in the four categories of publishing, commercial printing, packaging/labels, specialties, and the environment. Primarily made from polypropylene resin, YUPO® is functional synthetic paper that has the special characteristics of being water-resistant, tear-resistant, and suitable for colorful printing. The exhibition introduced a wide range of actual examples that have functions that go even further than those characteristics, such as sheets that efficiently reflect light. Many visitors expressed great interest. Other examples displayed at the exhibition include FEBG 300 (released on March 1), a thick paper in the YUPO GREEN series of eco-friendly YUPO® containing biomass resin, as well as a biodegradable synthetic paper. Perhaps because of the recent increase in environmental awareness, these products have won attention from many visitors, and there are great expectations regarding future developments for YUPO®.



▶ KPP Chubu Branch Exhibits on Packaging in the Present and Future

Chubu Branch held the two-day exhibition, "Packaging in the Present and Future: Ideas for Promoting Customer Sales," on February 25 and 26. In addition to the manufacturing process for various packages and new materials such as bioplastic, the exhibition introduced a broad scope of eco-friendly products such as paper straws. The event also included a lecture titled, "The Basics of Biodegradable Plastic: What is PLA?" (held three times), given by guest speaker Kozo Ochi, an executive at MITOMO Co., Ltd. The exhibition was a success, with over 220 people visiting over the two days, which is more than the number of visitors last year.



KPP Group Overseas Network

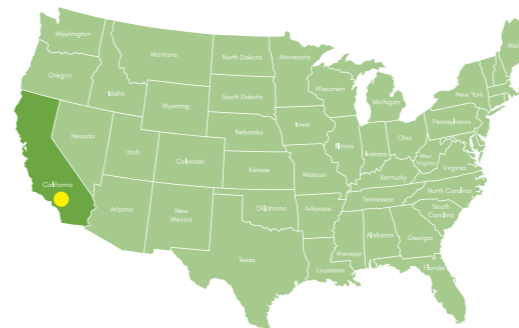

DaiEi Papers (USA) Corp.



INFO
10900 E 183rd St., Suite 241,
Cerritos, CA 90703, U.S.A.
TEL: 1-714-523-0900
FAX: 1-714-523-0919
E-Mail: la@daieipapers.com



PROFILE

KEY PERSON 1

Sales
Cal Aycock



Q1 Business Profile

General Sales Manager, Eastern U.S. Region

Q2 Personality

Outgoing, Type "A"

Q3 Motto

"Failure is Not An Option!"

After spending over 13 years with three U.S. paper companies, I crossed over to the trading side in 2002 when I took a sales manager's job with a Swedish firm. As they had very little business in the U.S. at the time, I was charged with essentially building a business from scratch. While it was a tough assignment (as mostly a pulp trading company, they had fewer paper mill relationships than DaiEi USA), I also believed that there was no going back to the "easier" mill side. So, on my first day, I wrote "Failure Is Not An Option!" in my day-timer, and have operated that way ever since, including the past nine years with my DaiEi USA team.

KEY PERSON 2

Logistics
Susan Kim



Q1 Business Profile

Responsible for multifunctional duties including order processing, coordinating export shipments, and inventory management

Q2 Personality

Adventurous

Q3 Motto

"The grass is greener where you water it."

Contrary to the famous saying "The grass is greener on the other side," I believe in being less concerned about comparisons with others and instead investing more focus on one's own pathway to success. I observe acknowledging satisfaction of one's own circumstances as the first step and then using "water" as the second which comes in various forms: setting achievable goals, commitment, productivity, etc. To envy is to waste time and energy.

OUR BUSINESS

USA is the world's biggest supplier of waste paper. About 130,000 tons of waste paper are collected every day. We have started exporting USA origin waste paper to the Asian market, and it is becoming a core businesses.

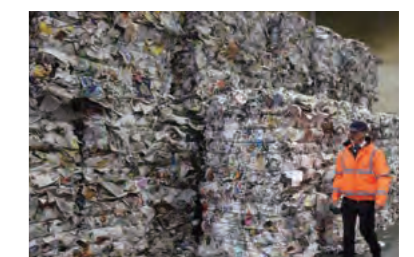

Source: Annual Statistical Summary of Recovered Paper Utilization, June 2018, American Forest & Paper Association.

April 8 – June 7

EXHIBITION

TSUNAGU GALLERY Vol. 9: Works by the Receipt Artist, VIKI Exhibition

Thermal paper changes color when heat is applied. VIKI takes advantage of this property to create unique artwork by applying heat to a myriad of receipts pasted on a canvas. The art is produced by effectively combining elements such as lines of varying thickness and gradated shades. Don't miss this chance to see the world of "receipt art" for yourself.

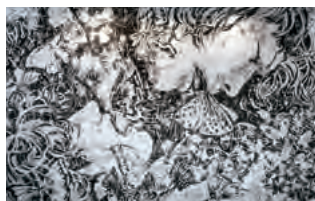

Psyche's Eyelid

INFO

- Venue: Kokusai Pulp & Paper Co., Ltd.
Head Office, 1st-floor entrance
6-24 Akashi-cho, Chuo-ku, Tokyo
- Admission: Free
- Contact: IR & Public Relations Section, Corporate Planning Department
- TEL: +81-3-3542-4169
- URL: www.kppc.co.jp

June 6 – 10

EVENT

Shirone Giant Kite Battle

The world's largest kite-flying competition takes place on opposing east-west banks over the Nakanokuchi-gawa River, a branch of the Shinano-gawa River. Enjoy the heat of this thrilling battle in the skies, fought by giant kites that are each about 40m². Competitors aim to tangle each other's kites in the air to bring them down into the river, and win by pulling until the other competitor's kite rope breaks.



©Shirone Giant Kite Battle

INFO

- Venue: Banks of the Nakanokuchi-gawa River, Shirone/Nishishirone, Minami-ku, Niigata City (between Takomi-bashi Bridge and Shirone-bashi Bridge)
- Admission: Free (viewing seats available for a fee)
- Contact: Shirone Giant Kite Battle Executive Committee (inside Industry Promotion Division, Minami Ward Office, Niigata City)
- TEL: +81-25-372-6505
- URL: www.shironekankou.jp/tako

April 14 – June 30

EXHIBITION

Commemorative Exhibition Akira Yoshizawa's World of Origami

This exhibition is a priceless collection of artwork donated by Akira Yoshizawa, the grandmaster of origami. Yoshizawa is known for the 3-dimensional figures he made by folding a single piece of paper. Based on the motif of all things in nature, his origami creations almost seem alive. In addition to this recently donated artwork, there are about 600 other pieces of art, such as mobiles, now on display for the first time at the Sano Art Museum.



Monkeys in a variety of poses



Akita Inu dog

The artwork printed in this publication is property of the Sano Art Museum.

INFO

- Venue: Sano Art Museum 1-43 Nakata-machi, Mishima City, Shizuoka Prefecture
- Admission: 1,000 yen general public or university students; 500 yen elementary, jr. high, or high school students
- Contact: Sano Art Museum
- TEL: +81-55-975-7278
- URL: www.sanoji.or.jp

April 13 – 14

EVENT

Mino Festival

The festival at Hachiman-jinja Shrine is celebrated in three parts: the flower *mikoshi* (portable shrines), festival floats, and *nagashi niwaka* (impromptu skits). Flower *mikoshi* decorated with approximately 300 flowers made from Mino *washi* paper dyed cherry-blossom pink are paraded through the old streets lined with traditional Udatsu housing. This event heralds the arrival of spring in this town known for producing Japanese *washi* paper.

INFO

- Venue: Udatsu no Agaru Machinami vicinity, Hachiman-jinja Shrine (Kamijo, Mino City, Gifu Prefecture)
- Admission: Free
- Contact: Mino Washi Paper Promotion Section, Industry Promotion Department, Mino City
- TEL: +81-575-33-1122
- URL: www.city.mino.gifu.jp

April 27 – 28

EVENT

Tegamisha Children's Day

This special event is full of hands-on experiences for children. It is jam-packed with exciting content in five spaces, including the Picture Book Forest where children can meet their favorite picture book authors, and Craft Town, which features workshops by authors.

INFO

- Venue: Tokyo Metropolitan Industrial Trade Center Taito-kan 7th-floor Exhibition Hall 2-6-5 Hanakawado, Taito-ku, Tokyo
- Admission: 500 yen (free for children up to 1 year old)
- Contact: Tegamisha
- TEL: +81-42-444-5367
- URL: http://kodomonohji.jp

*Please check the websites of the above-mentioned organizations for information about open days and hours.
*The events and exhibitions may be subject to change for various reasons. Before visiting, please confirm in advance if each event and exhibition is open according to schedule by website or telephone.



We have adopted a bookbinding method free of staples, paste and heat, taking into consideration recycling and the risk of injuries.



国際紙パルプ商事株式会社
KOKUSAI PULP&PAPER CO.,LTD.

Published by IR & Public Relations Section,
Corporate Planning Dept., Corporate Planning Div.
Address: 6-24 Akashi-cho, Chuo-ku, Tokyo, Japan
TEL: +81-3-3542-4111 (main switchboard number)
Website: <http://www.kppc.co.jp/>

Braided Bird Plate by Yasuyuki Wada

Try making a paper craft by Yasuyuki Wada that was introduced on the Special Feature page. Use it on your desk as a tray to hold small items such as paperclips, or to add a nice touch to accent a room. When placed on your desk or living space, the cute little bird paper craft signals the start of spring.

*This craft was created by Yasuyuki Wada and appears in *Kami no Hako to Utsuwa* ("Paper Boxes and Containers," Bunka Publishing Bureau).

Mountain-fold line - - - - -

Valley-fold line - - - - -

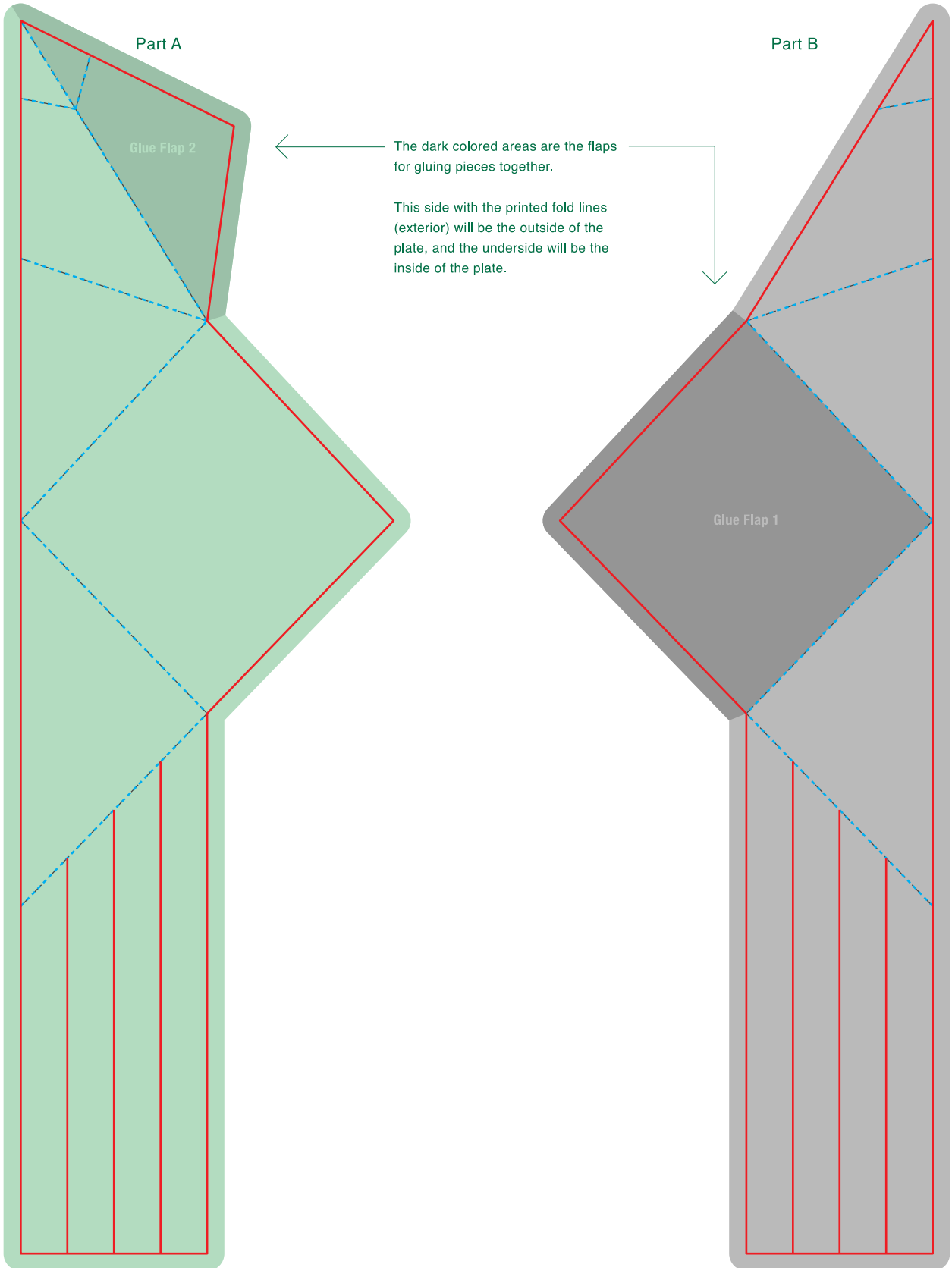

Instructions

1 Cut out Part A and Part B and fold along the mountain-fold and valley-fold lines.

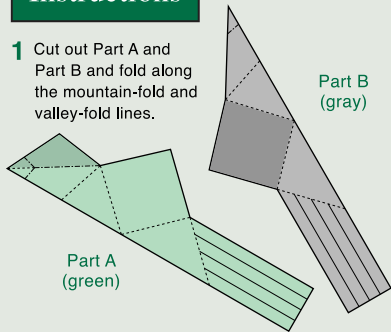

2 After folding along all lines, match up "Flap 1" and glue together Part A and Part B as shown in the illustration. Next, glue "Flap 2."

Part B (top)

Part A (bottom)

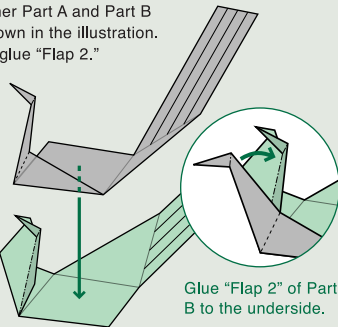

Glue "Flap 2" of Part B to the underside.

3 Braid the tails together.

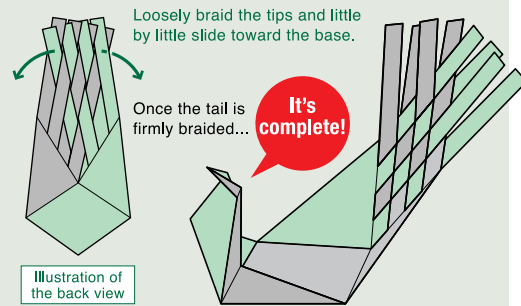

Loosely braid the tips and little by little slide toward the base.

Once the tail is firmly braided...

It's complete!

Illustration of the back view

